

8 7 6 5 4 3 2 1

THIS DRAWING & SPECIFICATIONS ARE PROPERTY OF MORGANTON PRESSURE VESSELS AND MAY NOT BE COPIED, REPRODUCED, OR USED IN WHOLE OR PART, AS A BASIS FOR DESIGN MANUFACTURE OR SALE WITHOUT PRIOR PERMISSION FROM MORGANTON PRESSURE VESSELS.

DESIGN INFORMATION	
SPECIFICATION	VALUE
DIAMETER (O.D.)	30.000"
MAWP	200 PSI AT 650°F
MDMT	-20°F AT 200 PSI
CAPACITY	APPROX 200 GALLONS
APPROX. WEIGHT	620 LBS

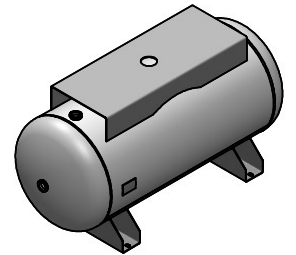
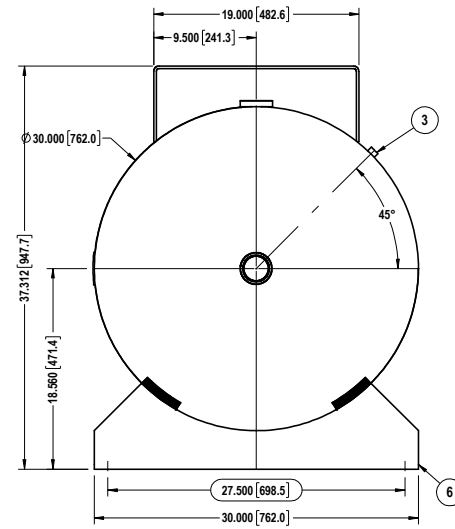
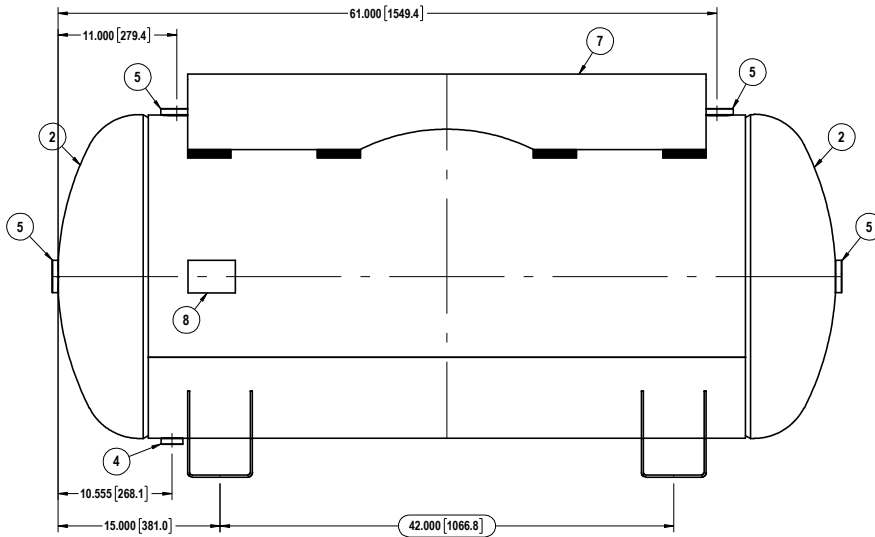
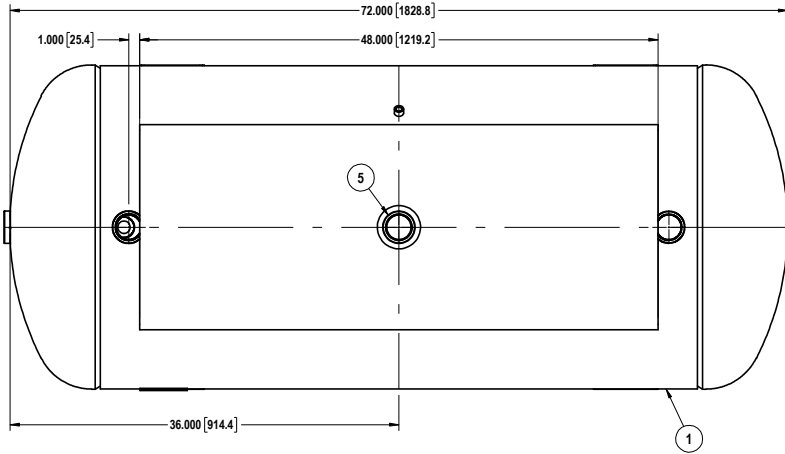

ITEM#	DESCRIPTION	QTY.
8	NAME PLATE	1
7	TOP PLATE	1
6	LEG	2
5	2" NPT COUPLING	5
4	1" NPT COUPLING	1
3	1/4" NPT COUPLING	1
2	HEAD	2
1	SHELL	1

NOT FOR PRODUCTION USE

MORGANTON
 200 GALLON
 HORIZONTAL VESSEL
 -ASME-
 SEC. VIII DIV. 1

TOLERANCES, IF NOT INDICATED, ACCORDING TO:
 C-G SE 03.03 / 3

DWG. NO.
VES09300

8 7 6 5 4 3 2 1