

8 7 6 5 4 3 2 1

THIS DRAWING & SPECIFICATIONS ARE PROPERTY OF MORGANTON PRESSURE VESSELS AND MAY NOT BE COPIED, REPRODUCED, OR USED IN WHOLE OR PART, AS A BASIS FOR DESIGN MANUFACTURE OR SALE WITHOUT PRIOR PERMISSION FROM MORGANTON PRESSURE VESSELS.

DESIGN INFORMATION	
SPECIFICATION	VALUE
DIAMETER (O.D.)	16.000"
MAWP	200 PSI AT 650°F
MDMT	-20°F AT 200 PSI
CAPACITY	APPROX 30 GALLONS
APPROX. WEIGHT	94 LBS

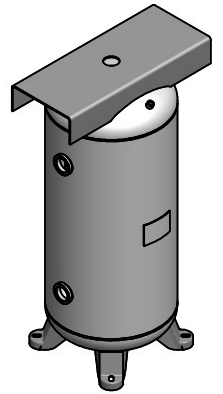
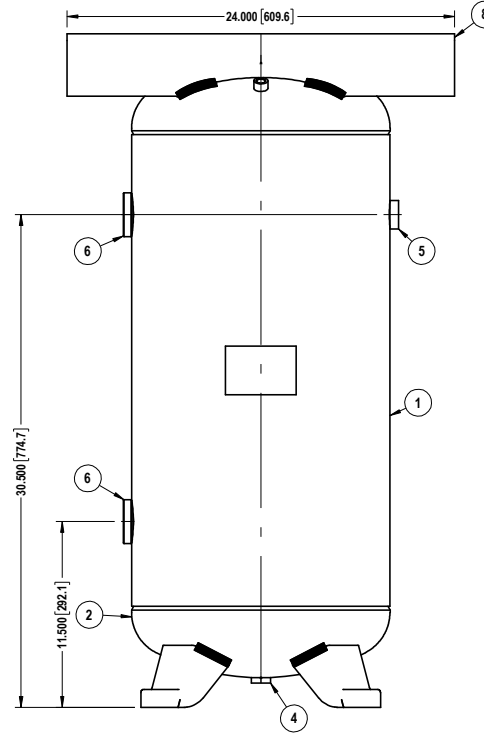
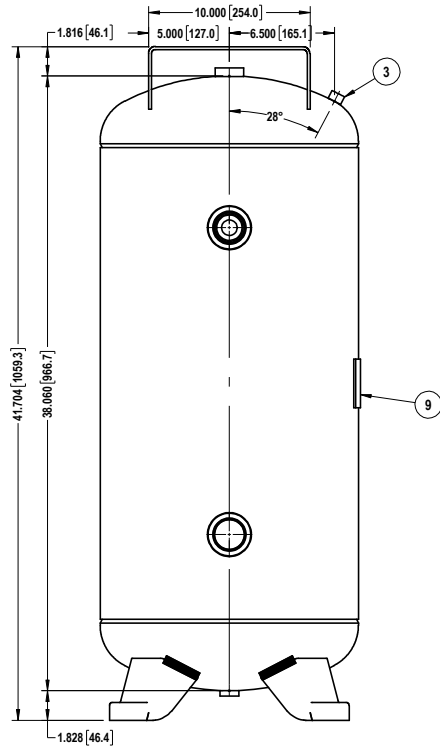
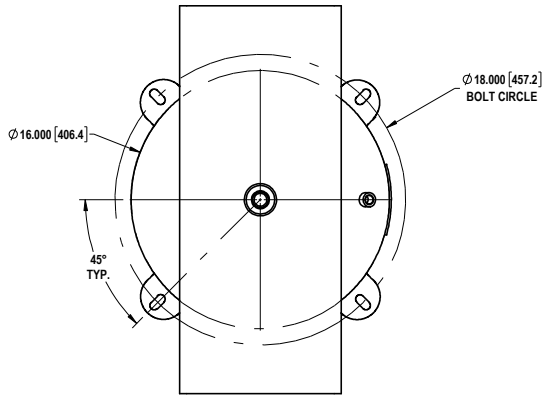

ITEM#	DESCRIPTION	QTY.
9	NAME PLATE	1
8	TOP PLATE	1
7	LEG	4
6	1-1/2" NPT COUPLING	2
5	3/4" NPT COUPLING	2
4	1/2" NPT COUPLING	1
3	1/4" NPT COUPLING	1
2	HEAD	1
1	SHELL	1

MORGANTON

30 GALLON
VERT. AIR RECEIVER
-ASME-
SEC. VIII DIV. 1

TOLERANCES, IF NOT INDICATED, ACCORDING TO:

C-G SE 03.03 / 3

DWG. NO.

VES09121

NOT FOR PRODUCTION USE

8 7 6 5 4 3 2 1