

8 7 6 5 4 3 2 1

THIS DRAWING & SPECIFICATIONS ARE PROPERTY OF MORGANTON PRESSURE VESSELS AND MAY NOT BE COPIED, REPRODUCED, OR USED IN WHOLE OR PART, AS A BASIS FOR DESIGN MANUFACTURE OR SALE WITHOUT PRIOR PERMISSION FROM MORGANTON PRESSURE VESSELS.

DESIGN INFORMATION	
SPECIFICATION	VALUE
DIAMETER (O.D.)	14.000"
MAWP	200 PSI AT 650°F
MDMT	-20°F AT 200 PSI
CAPACITY	APPROX 20 GALLONS
APPROX. WEIGHT	57 LBS

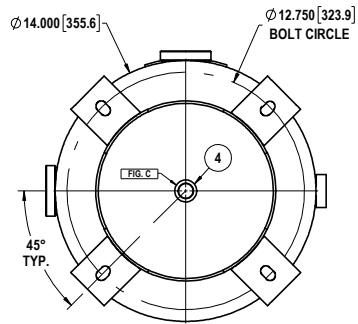
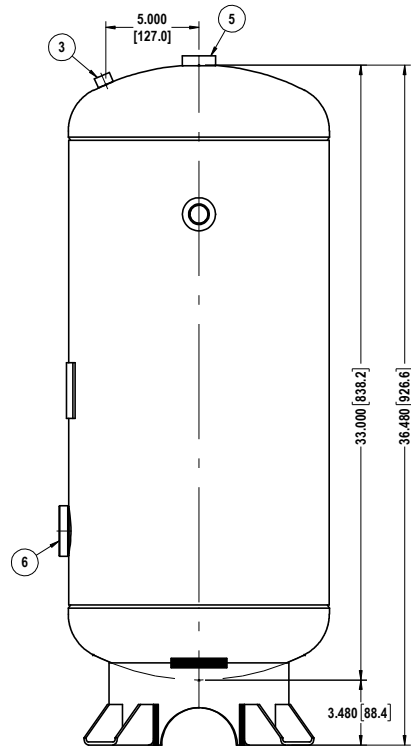
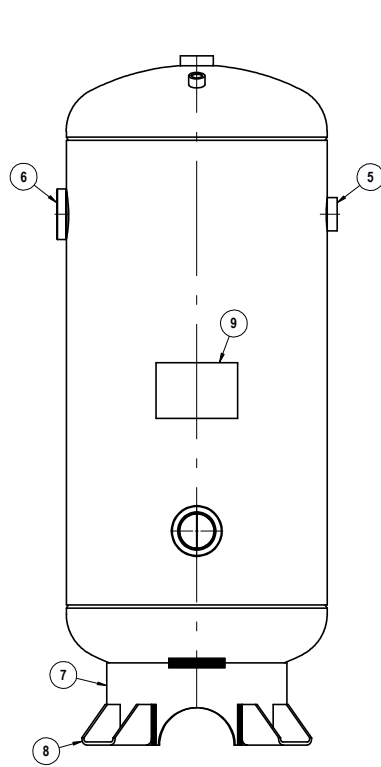

ITEM#	DESCRIPTION	QTY.
9	NAME PLATE	1
8	SKIRT SUPPORT	4
7	SKIRT	1
6	1-1/2" NPT COUPLING	2
5	3/4" NPT COUPLING	2
4	1/2" NPT COUPLING	1
3	1/4" NPT COUPLING	1
2	HEAD	2
1	SHELL	1

 -ASME- 20 GALLON VERTICAL VESSEL	TOLERANCES, IF NOT INDICATED, ACCORDING TO: C-G SE 03.03 / 3
	DIWG. NO. VES08573
	REV. 0

NOT FOR PRODUCTION USE

8 7 6 5 4 3 2 1