

THIS DRAWING & SPECIFICATIONS ARE PROPERTY OF MORGANTON PRESSURE VESSELS AND MAY NOT BE COPIED, REPRODUCED, OR USED IN WHOLE OR PART, AS A BASIS FOR DESIGN MANUFACTURE OR SALE WITHOUT PRIOR PERMISSION FROM MORGANTON PRESSURE VESSELS.

DESIGN INFORMATION	
SPECIFICATION	VALUE
DIAMETER (O.D.)	20.000"
MAWP	200 PSI AT 650°F
MDMT	-20°F AT 200 PSI
CAPACITY	APPROX 60 GALLONS
APPROX. WEIGHT	115 LBS

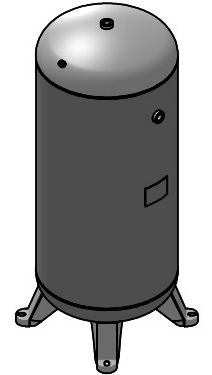
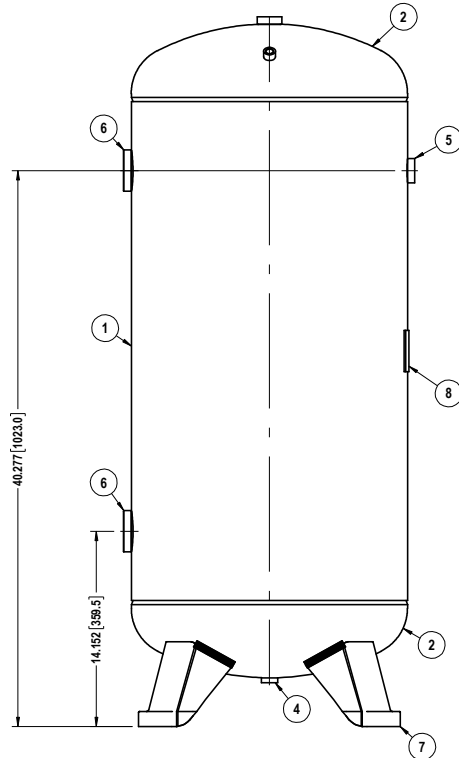
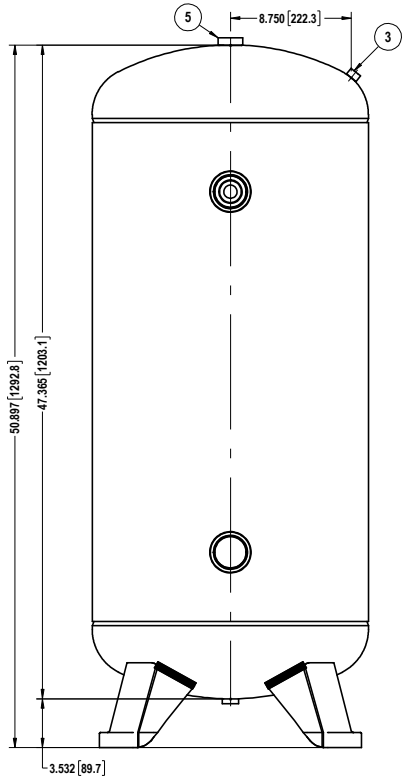
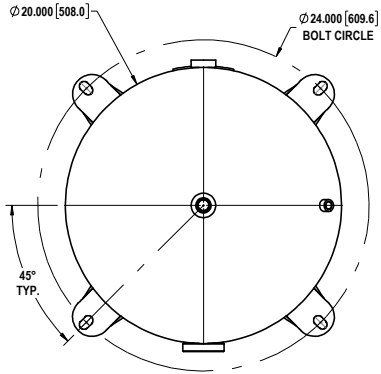

ITEM#	DESCRIPTION	QTY.
8	NAME PLATE	1
7	FOOT	4
6	2" NPT COUPLING	2
5	3/4" NPT COUPLING	2
4	1/2" NPT COUPLING	1
3	1/4" NPT COUPLING	1
2	HEAD	2
1	SHELL	1

MORGANTON

60 GALLON
VERT. AIR RECEIVER
-ASME-
SEC. VIII DIV. 1

TOLERANCES, IF NOT INDICATED, ACCORDING TO:
C-G SE 03.03 / 3
DWG. NO. VES04882

NOT FOR PRODUCTION USE