

THIS DRAWING & SPECIFICATIONS ARE PROPERTY OF MORGANTON PRESSURE VESSELS AND MAY NOT BE COPIED, REPRODUCED, OR USED IN WHOLE OR PART, AS A BASIS FOR DESIGN MANUFACTURE OR SALE WITHOUT PRIOR PERMISSION FROM MORGANTON PRESSURE VESSELS.

DESIGN INFORMATION	
SPECIFICATION	VALUE
DIAMETER (O.D.)	24.000"
MAWP	200 PSI AT 650°F
MDMT	-20°F AT 200 PSI
CAPACITY	APPROX XXX GALLONS
APPROX. WEIGHT	XXX LBS

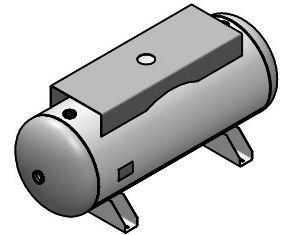
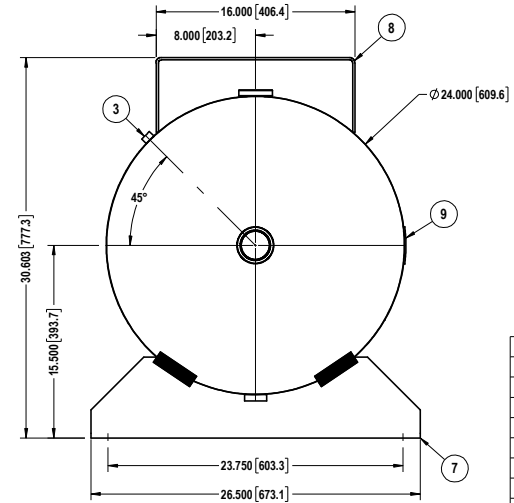
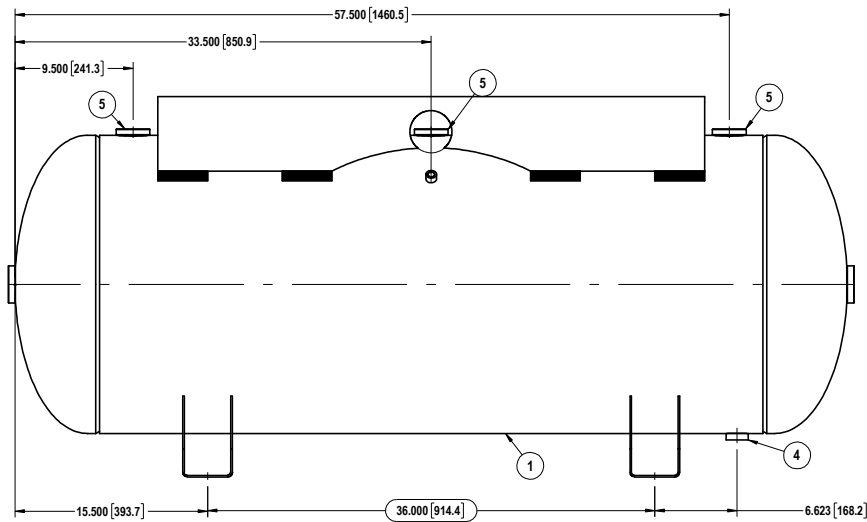
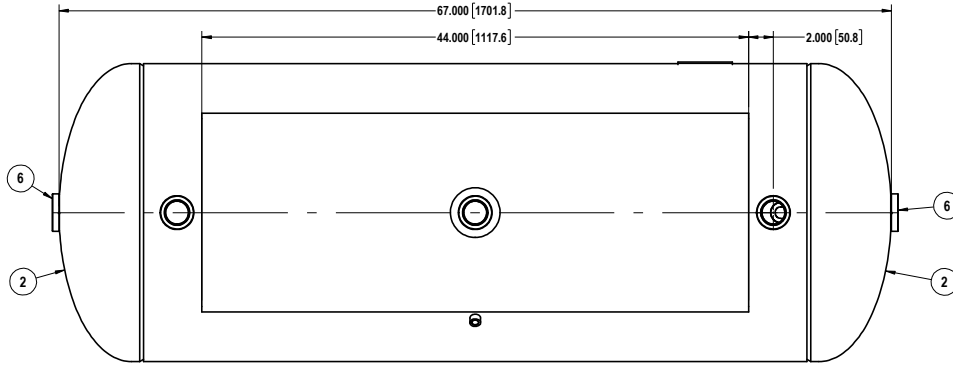

ITEM#	DESCRIPTION	QTY.
9	NAME PLATE	1
8	TOP PLATE	1
7	LEG	2
6	2" NPT COUPLING	2
5	1-1/2" NPT COUPLING	3
4	3/4" NPT COUPLING	1
3	1/4" NPT COUPLING	1
2	HEAD	2
1	SHELL	1

MORGANTON

120 GALLON
HORIZONTAL VESSEL
-ASME-
SEC. VIII DIV. 1

TOLERANCES, IF NOT INDICATED, ACCORDING TO:
C-G SE 03.03 / 3
DWG. NO. VES04769

NOT FOR PRODUCTION USE