

THIS DRAWING & SPECIFICATIONS ARE PROPERTY OF MORGANTON PRESSURE VESSELS AND MAY NOT BE COPIED, REPRODUCED, OR USED IN WHOLE OR PART, AS A BASIS FOR DESIGN, MANUFACTURE, OR SALE WITHOUT PRIOR PERMISSION FROM MORGANTON PRESSURE VESSELS.

DESIGN INFORMATION	
SPECIFICATION	VALUE
DIAMETER (O.D.)	36.000"
MAWP	165 PSI AT 650°F
MDMT	-20°F AT 165 PSI
CAPACITY	APPROX 400 GALLONS
APPROX. WEIGHT	690 LBS

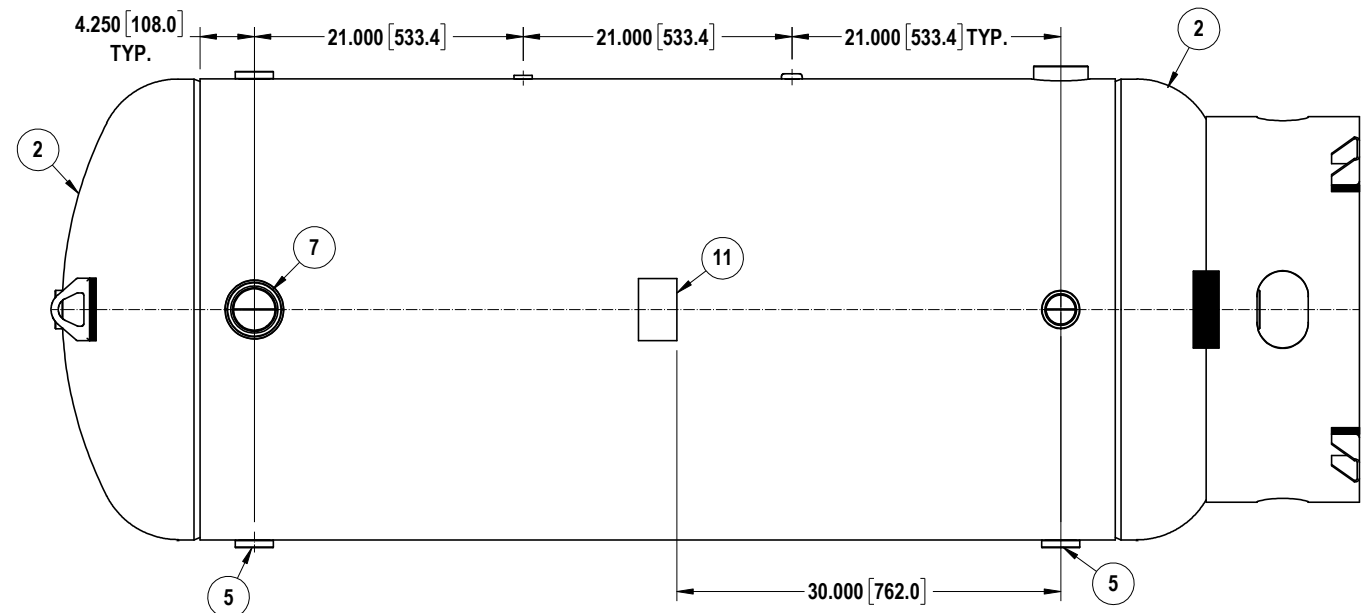
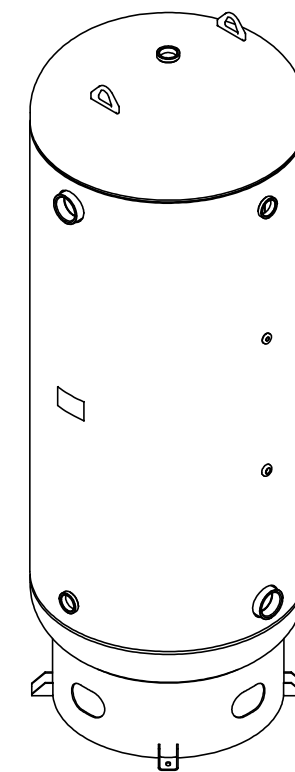
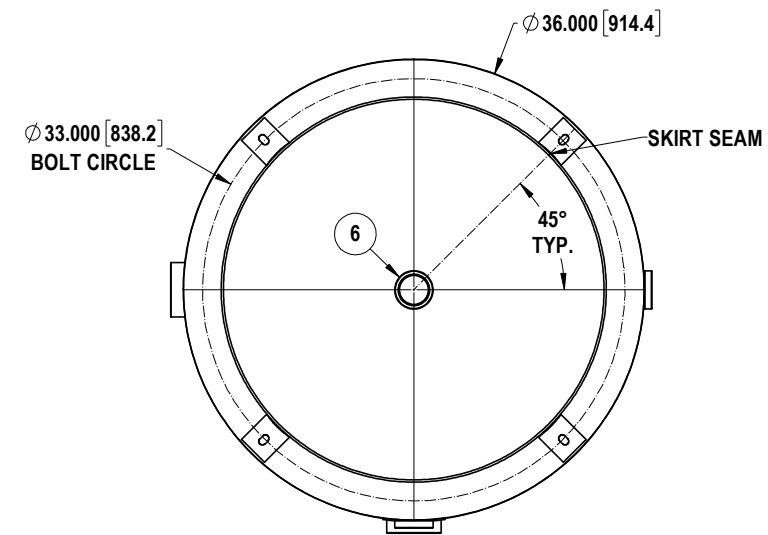
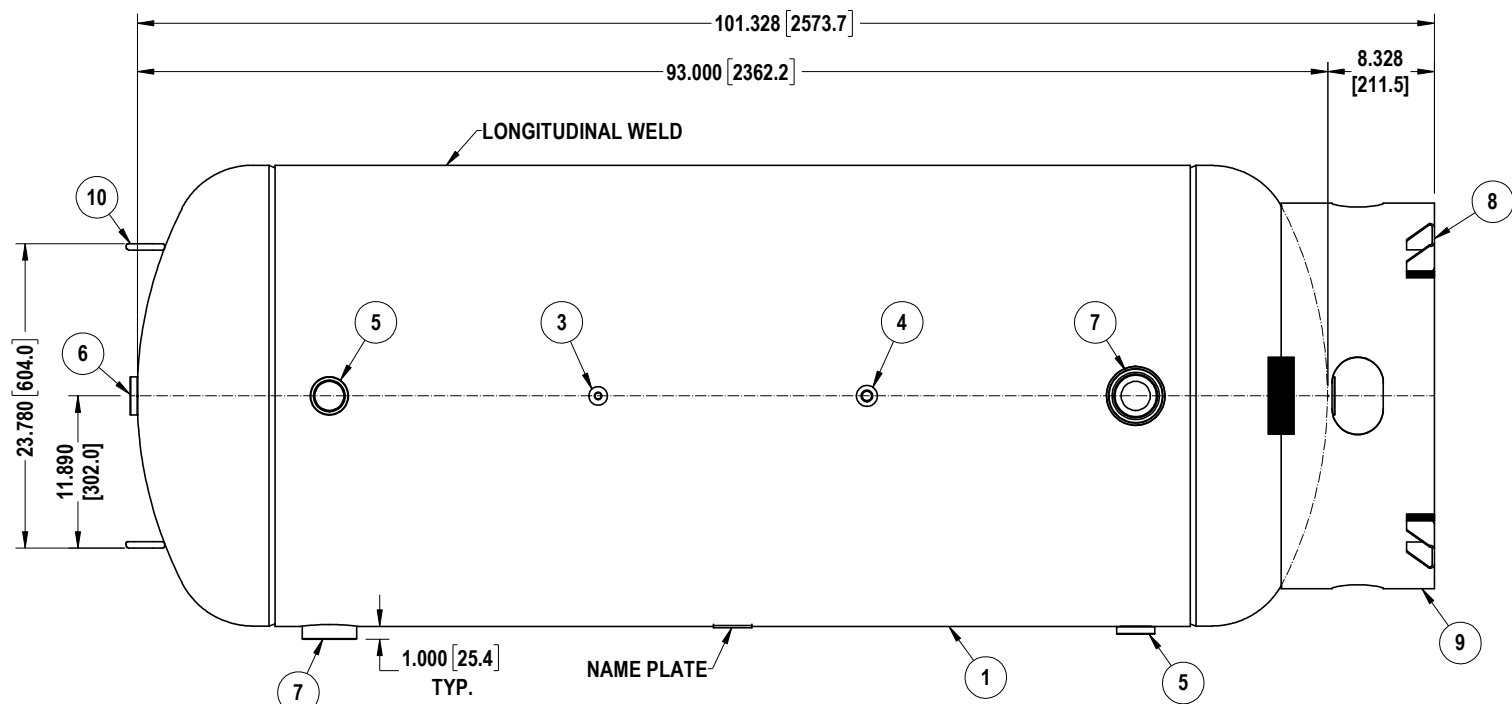

11	NAME PLATE	1
10	LIFTING LUG	2
9	36" SKIRT	1
8	SKIRT SUPPORT	4
7	3" NPT HALF COUPLING	2
6	2" NPT COUPLING	2
5	2" NPT COUPLING - PROFILED	4
4	1/2" NPT FLAT COUPLING	1
3	1/4" NPT FLAT COUPLING	1
2	HEAD	2
1	SHELL	1
ITEM#	DESCRIPTION	QTY.

MORGANTON -ASME- SECTION VIII DIV. 1 400 GALLON VERTICAL AIR RECEIVER	TOLERANCES, IF NOT INDICATED, ACCORDING TO: C-G SE 03.03 / 3
	DWG. NO. VES0010327
	NOT FOR PRODUCTION USE