

THIS DRAWING & SPECIFICATIONS ARE PROPERTY OF MORGANTON PRESSURE VESSELS AND MAY NOT BE COPIED, REPRODUCED, OR USED IN WHOLE OR PART, AS A BASIS FOR DESIGN MANUFACTURE OR SALE WITHOUT PRIOR PERMISSION FROM MORGANTON PRESSURE VESSELS.

DESIGN INFORMATION	
SPECIFICATION	VALUE
DIAMETER (O.D.)	10.000"
MAWP	200 PSI AT 650°F
MDMT	-20°F AT 200 PSI
CAPACITY	APPROX 10 GALLONS
APPROX. WEIGHT	35 LBS

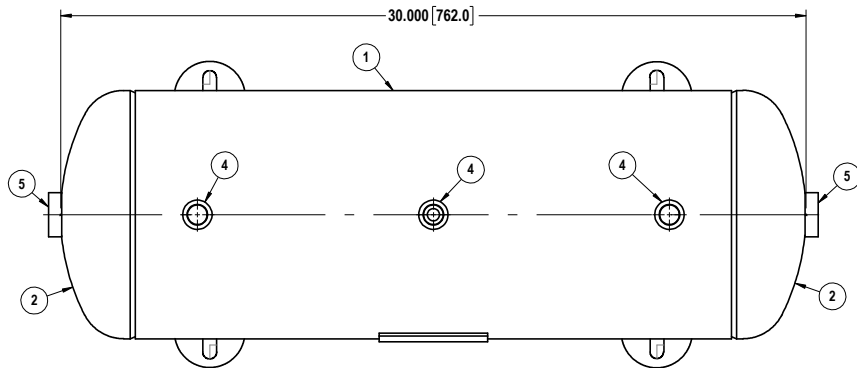
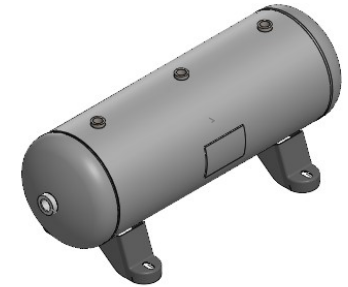
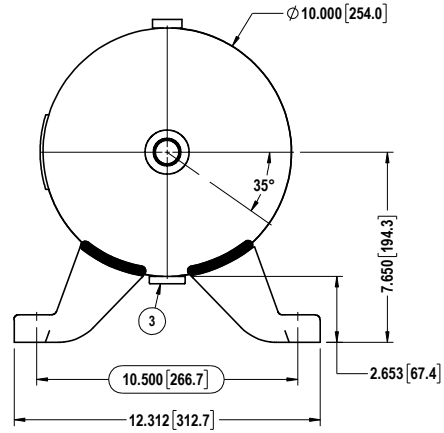
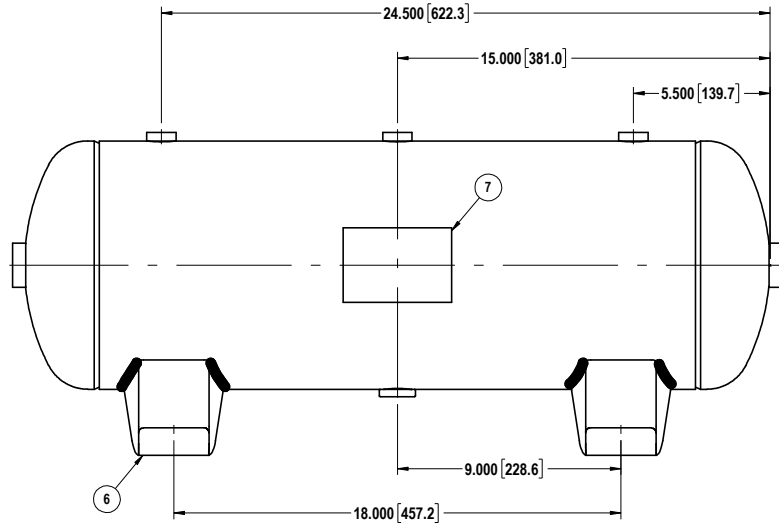

TOP VIEW

ITEM#	DESCRIPTION	QTY.
7	NAME PLATE	1
6	LEG	4
5	3/4" NPT COUPLING	2
4	1/2" NPT COUPLING	3
3	1/4" NPT FLAT COUPLING	1
2	HEAD	2
1	SHELL	1

	TOLERANCES, IF NOT INDICATED, ACCORDING TO: C-G SE 03.03 / 3
	DWG. NO. <b>VES0010059</b>
	REV. 0

NOT FOR PRODUCTION USE