

Metal Push-to-Connect Fitting - Union (PN26)

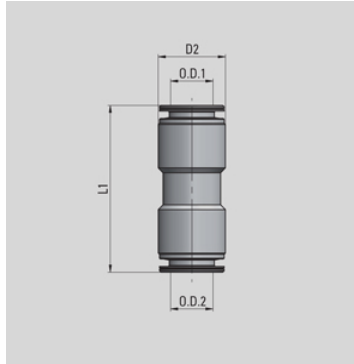

Part Number	Tube OD1	Tube OD2	D2	L1	OZ
PN26 1/8 1/8	1/8"	1/8"	0.275	0.866	0.106
PN26 5/32 5/32	5/32"	5/32"	0.354	1.062	0.265
PN26 1/4 1/4	1/4"	1/4"	0.472	1.299	0.476
PN26 5/16 5/16	5/16"	5/16"	0.551	1.299	0.635
PN26 3/8 3/8	3/8"	3/8"	0.629	1.456	0.882
PN26 1/2 1/2	1/2"	1/2"	0.748	1.535	1.111

Recommended Tightening Torque

Thread	Norm Reference	Tightening Torque (lb-ft)													
		M3x0.5	M5x0.8	M6x1	M7x1	M8x1	M10x1	M12x1.25	M12x1.5	10-32	1/8	1/4	3/8	1/2	
NPTF PTFE Pre-Coated	ANSI/ASME B1.20.3	-	-	-	-	-	-	-	-	-	-	8.5	10.5	13.5	18.5
UNF with O-Ring	ANSI/ASME B1.1	-	-	-	-	-	-	-	-	-	0.59	-	-	-	-
easyThread	Universal Thread	-	-	-	-	-	-	-	-	-	-	0.89	1.11	1.84	2.58
Gas Parallel with O-Ring	UNI - ISO 228/1	-	-	-	-	-	-	-	-	-	-	0.89	1.11	1.84	2.58
Gas Taper PTFE Pre-Coated	UNI - ISO 7/1	-	-	-	-	-	-	-	-	-	-	1.84	2.58	4.43	8.85
Gas Parallel with Plastic Ring	UNI - ISO 228/1	-	-	-	-	-	-	-	-	-	-	1.48	2.21	2.95	5.9
Metric with O-Ring	ISO R/262	0.59	0.59	0.59	0.59	-	-	1.11	1.11	-	-	-	-	-	-