

**Metal Push-to-Connect Fitting - Reducer (PN25)**

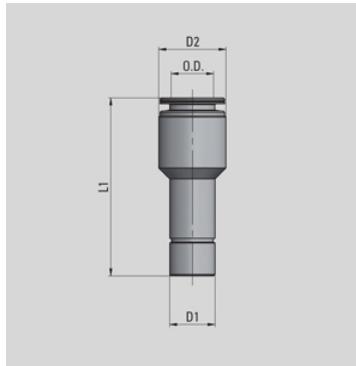

Part Number	Tube OD	D1	D2	L1	OZ
PN25 1/8 5/32	1/8"	5/32"	0.275	1.141	0.088
PN25 5/32 1/4	5/32"	1/4"	0.354	1.22	0.265
PN25 1/4 5/16	1/4"	5/16"	0.472	1.299	0.406
PN25 1/4 3/8		3/8"	0.472	1.377	0.476
PN25 1/4 1/2		1/2"	0.472	1.377	0.882
PN25 5/16 3/8	5/16"	3/8"	0.551	1.377	0.547
PN25 3/8 1/2	3/8"	1/2"	0.629	1.417	0.864

**Recommended Tightening Torque**

Thread	Norm Reference	Tightening Torque (lb-ft)													
		M3x0.5	M5x0.8	M6x1	M7x1	M8x1	M10x1	M12x1.25	M12x1.5	10-32	1/8	1/4	3/8	1/2	
NPTF PTFE Pre-Coated	ANSI/ASME B1.20.3	-	-	-	-	-	-	-	-	-	-	8.5	10.5	13.5	18.5
UNF with O-Ring	ANSI/ASME B1.1	-	-	-	-	-	-	-	-	0.59	-	-	-	-	
easyThread	Universal Thread	-	-	-	-	-	-	-	-	-	0.89	1.11	1.84	2.58	
Gas Parallel with O-Ring	UNI - ISO 228/1	-	-	-	-	-	-	-	-	-	0.89	1.11	1.84	2.58	
Gas Taper PTFE Pre-Coated	UNI - ISO 7/1	-	-	-	-	-	-	-	-	-	1.84	2.58	4.43	8.85	
Gas Parallel with Plastic Ring	UNI - ISO 228/1	-	-	-	-	-	-	-	-	-	1.48	2.21	2.95	5.9	
Metric with O-Ring	ISO R/262	0.59	0.59	0.59	0.59	-	-	1.11	1.11	-	-	-	-	-	