

Metal Push-to-Connect Fitting - Swivelling Tee, Taper (PN20)

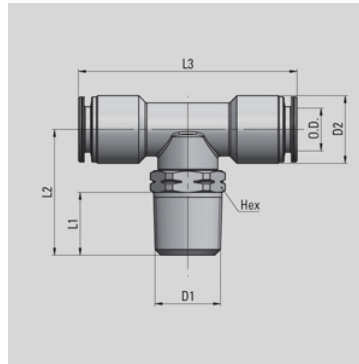

Part Number	Tube OD	D1 NPT	D2	L1	L2	L3	HEX	OZ
PN20 1/8 1/8	1/8"	1/8	0.275	0.334	0.728	1.141	7/16"	0.67
PN20 5/32 1/8	5/32"	1/8	0.354	0.334	0.826	1.496	1/2"	0.776
PN20 5/32 1/4		1/4	0.354	0.511	1.023	1.496	9/16"	0.97
PN20 1/4 1/8	1/4"	1/8	0.472	0.334	0.826	1.692	1/2"	0.917
PN20 1/4 1/4		1/4	0.472	0.511	1.023	1.692	9/16"	1.076
PN20 5/16 1/8	5/16"	1/8	0.551	0.334	0.826	1.732	1/2"	1.111
PN20 5/16 1/4		1/4	0.551	0.511	1.023	1.732	9/16"	1.305
PN20 3/8 1/4	3/8"	1/4	0.629	0.511	1.122	1.968	11/16"	1.905
PN20 3/8 3/8		3/8	0.629	0.511	1.122	1.968	11/16"	1.94
PN20 1/2 3/8	1/2"	3/8	0.748	0.511	1.259	2.165	13/16"	2.751
PN20 1/2 1/2		1/2	0.748	0.669	1.437	2.165	7/8"	3.175

Recommended Tightening Torque

Thread	Norm Reference	Tightening Torque (lb-ft)													
		M3x0.5	M5x0.8	M6x1	M7x1	M8x1	M10x1	M12x1.25	M12x1.5	10-32	1/8	1/4	3/8	1/2	
NPTF PTFE Pre-Coated	ANSI/ASME B1.20.3	-	-	-	-	-	-	-	-	-	-	8.5	10.5	13.5	18.5
UNF with O-Ring	ANSI/ASME B1.1	-	-	-	-	-	-	-	-	0.59	-	-	-	-	
easyThread	Universal Thread	-	-	-	-	-	-	-	-	-	0.89	1.11	1.84	2.58	
Gas Parallel with O-Ring	UNI - ISO 228/1	-	-	-	-	-	-	-	-	-	0.89	1.11	1.84	2.58	
Gas Taper PTFE Pre-Coated	UNI - ISO 7/1	-	-	-	-	-	-	-	-	-	1.84	2.58	4.43	8.85	
Gas Parallel with Plastic Ring	UNI - ISO 228/1	-	-	-	-	-	-	-	-	-	1.48	2.21	2.95	5.9	
Metric with O-Ring	ISO R/262	0.59	0.59	0.59	0.59	-	-	1.11	1.11	-	-	-	-	-	