

Metal Push-to-Connect Fitting - Taper Swivelling Elbow, Male (PN15)

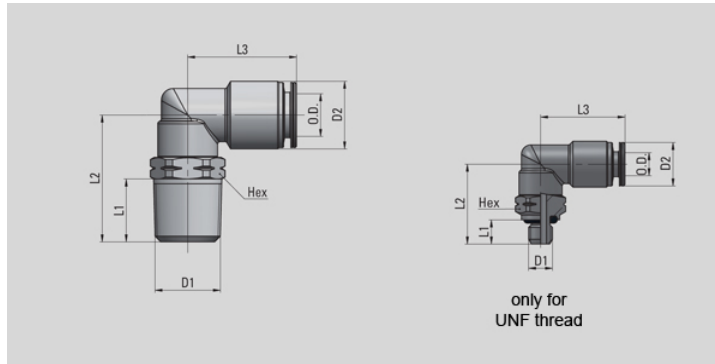

Part Number	Tube OD	D1 UNF	D1 NPT	D2	L1	L2	L3	HEX	OZ
PN15 1/8 10-32	1/8"	10-32	-	0.275	0.196	0.649	0.57	3/8"	0.282
PN15 5/32 10-32	5/32"	10-32	-	0.354	0.196	0.649	0.669	3/8"	0.353
PN15 1/8 1/8	1/8"	-	1/8	0.275	0.334	0.728	0.57	7/16"	0.37
PN15 5/32 1/8	5/32"	-	1/8	0.354	0.334	0.728	0.669	7/16"	0.441
PN15 5/32 1/4		-	1/4	0.354	0.511	1.023	0.748	9/16"	0.794
PN15 1/4 1/8	1/4"	-	1/8	0.472	0.334	0.826	0.846	1/2"	0.688
PN15 1/4 1/4		-	1/4	0.472	0.511	1.023	0.846	9/16"	0.882
PN15 1/4 3/8		-	3/8	0.472	0.512	1.043	0.866	11/16"	-
PN15 5/16 1/8	5/16"	-	1/8	0.551	0.334	0.826	0.866	1/2"	0.811
PN15 5/16 1/4		-	1/4	0.551	0.511	1.023	0.866	9/16"	1.005
PN15 5/16 3/8		-	3/8	0.551	0.511	1.122	0.885	11/16"	1.411
PN15 3/8 1/8	3/8"	-	1/8	0.629	0.334	0.944	0.984	11/16"	1.376
PN15 3/8 1/4		-	1/4	0.629	0.511	1.122	0.984	11/16"	1.499
PN15 3/8 3/8		-	3/8	0.629	0.511	1.122	0.984	11/16"	1.534
PN15 3/8 1/2		-	1/2	0.629	0.669	1.338	0.984	7/8"	2.187
PN15 1/2 1/4	1/2"	-	1/4	0.748	0.511	1.259	1.082	13/16"	2.346
PN15 1/2 3/8		-	3/8	0.748	0.511	1.259	1.082	13/16"	2.222
PN15 1/2 1/2		-	1/2	0.748	0.669	1.437	1.082	7/8"	2.663

Recommended Tightening Torque

Thread	Norm Reference	Tightening Torque (lb-ft)													
		M3x0.5	M5x0.8	M6x1	M7x1	M8x1	M10x1	M12x1.25	M12x1.5	10-32	1/8	1/4	3/8	1/2	
NPTF PTFE Pre-Coated	ANSI/ASME B1.20.3	-	-	-	-	-	-	-	-	-	-	8.5	10.5	13.5	18.5
UNF with O-Ring	ANSI/ASME B1.1	-	-	-	-	-	-	-	-	0.59	-	-	-	-	
easyThread	Universal Thread	-	-	-	-	-	-	-	-	-	0.89	1.11	1.84	2.58	
Gas Parallel with O-Ring	UNI - ISO 228/1	-	-	-	-	-	-	-	-	-	0.89	1.11	1.84	2.58	
Gas Taper PTFE Pre-Coated	UNI - ISO 7/1	-	-	-	-	-	-	-	-	-	1.84	2.58	4.43	8.85	
Gas Parallel with Plastic Ring	UNI - ISO 228/1	-	-	-	-	-	-	-	-	-	1.48	2.21	2.95	5.9	
Metric with O-Ring	ISO R/262	0.59	0.59	0.59	0.59	-	-	1.11	1.11	-	-	-	-	-	