

**Metal Push-to-Connect Fitting - Female Straight (PN13)**

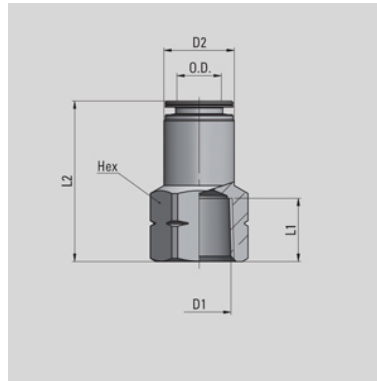

| Part Number   | Tube OD | D1 NPT | D2    | L1    | L2    | HEX    | OZ    |
|---------------|---------|--------|-------|-------|-------|--------|-------|
| PN13 5/32 1/8 | 5/32"   | 1/8    | 0.354 | 0.334 | 0.964 | 9/16"  | 0.423 |
| PN13 1/4 1/8  | 1/4"    | 1/8    | 0.472 | 0.334 | 1.043 | 9/16"  | 0.494 |
| PN13 1/4 1/4  |         | 1/4    | 0.472 | 0.511 | 1.22  | 11/16" | 0.935 |
| PN13 5/16 1/8 | 5/16"   | 1/8    | 0.551 | 0.334 | 1.039 | 9/16"  | 0.705 |
| PN13 5/16 1/4 |         | 1/4    | 0.551 | 0.511 | 1.22  | 11/16" | 1.005 |
| PN13 3/8 1/4  | 3/8"    | 1/4    | 0.629 | 0.511 | 1.299 | 11/16" | 1.164 |
| PN13 3/8 3/8  |         | 3/8    | 0.629 | 0.511 | 1.299 | 13/16" | 1.34  |

**Recommended Tightening Torque**

| Thread                         | Norm Reference    | Tightening Torque (lb-ft) |        |      |      |      |       |          |         |       |      |      |      |      |      |
|--------------------------------|-------------------|---------------------------|--------|------|------|------|-------|----------|---------|-------|------|------|------|------|------|
|                                |                   | M3x0.5                    | M5x0.8 | M6x1 | M7x1 | M8x1 | M10x1 | M12x1.25 | M12x1.5 | 10-32 | 1/8  | 1/4  | 3/8  | 1/2  |      |
| NPTF PTFE Pre-Coated           | ANSI/ASME B1.20.3 | -                         | -      | -    | -    | -    | -     | -        | -       | -     | -    | 8.5  | 10.5 | 13.5 | 18.5 |
| UNF with O-Ring                | ANSI/ASME B1.1    | -                         | -      | -    | -    | -    | -     | -        | -       | -     | 0.59 | -    | -    | -    | -    |
| easyThread                     | Universal Thread  | -                         | -      | -    | -    | -    | -     | -        | -       | -     | -    | 0.89 | 1.11 | 1.84 | 2.58 |
| Gas Parallel with O-Ring       | UNI - ISO 228/1   | -                         | -      | -    | -    | -    | -     | -        | -       | -     | -    | 0.89 | 1.11 | 1.84 | 2.58 |
| Gas Taper PTFE Pre-Coated      | UNI - ISO 7/1     | -                         | -      | -    | -    | -    | -     | -        | -       | -     | -    | 1.84 | 2.58 | 4.43 | 8.85 |
| Gas Parallel with Plastic Ring | UNI - ISO 228/1   | -                         | -      | -    | -    | -    | -     | -        | -       | -     | -    | 1.48 | 2.21 | 2.95 | 5.9  |
| Metric with O-Ring             | ISO R/262         | 0.59                      | 0.59   | 0.59 | 0.59 | -    | -     | -        | 1.11    | 1.11  | -    | -    | -    | -    | -    |