

Metal Push-to-Connect Fitting - Taper Straight, Male (PN11)

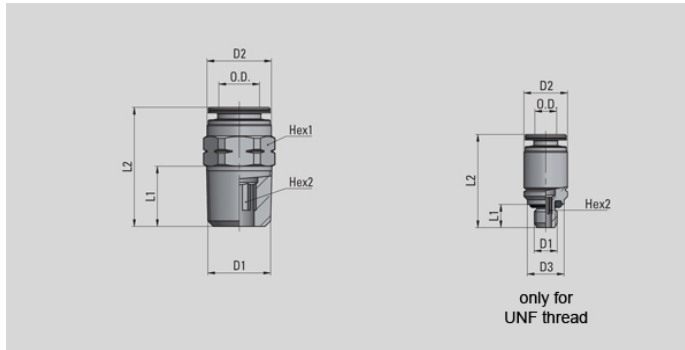

Part Number	Tube OD	D1 UNF	D1 NPT	D2	D3	L1	L2	HEX1	HEX2	OZ
PN11 1/8 10-32	1/8	10-32	-	0.276	0.315	0.197	0.657	-	3/32	0.088
PN11 5/32 10-32	5/32	10-32	-	0.374	0.315	0.197	0.787	-	3/32	0.159
PN11 1/4 10-32	1/4	10-32	-	0.472	0.315	0.197	0.925	-	3/32	0.3
PN11 1/8 1/8	1/8	-	1/8	0.276	-	0.335	0.728	7/16	3/32	0.335
PN11 5/32 1/8	5/32	-	1/8	0.374	-	0.335	0.728	7/16	1/8	0.318
PN11 5/32 1/4		-	1/4	0.374	-	0.512	0.945	9/16	1/8	0.706
PN11 1/4 1/8	1/4	-	1/8	0.472	-	0.335	0.866	1/2	5/32	0.371
PN11 1/4 1/4		-	1/4	0.472	-	0.512	0.965	9/16	5/32	0.653
PN11 1/4 3/8		-	3/8	0.472	-	0.512	1.004	11/16	5/32	-
PN11 5/16 1/8	5/16	-	1/8	0.551	-	0.335	1.043	9/16	3/16	0.529
PN11 5/16 1/4		-	1/4	0.551	-	0.512	1.004	9/16	1/4	0.565
PN11 5/16 3/8		-	3/8	0.551	-	0.512	0.984	11/16	1/4	0.988
PN11 3/8 1/8	3/8	-	1/8	0.63	-	0.335	1.122	11/16	3/16	0.794
PN11 3/8 1/4		-	1/4	0.63	-	0.512	1.26	11/16	1/4	0.953
PN11 3/8 3/8		-	3/8	0.63	-	0.512	1.004	11/16	5/16	0.9
PN11 3/8 1/2		-	1/2	0.63	-	0.669	1.201	7/8	5/16	1.976
PN11 1/2 1/4	1/2	-	1/4	0.787	-	0.512	1.358	13/16	5/16	1.253
PN11 1/2 3/8		-	3/8	0.787	-	0.512	1.161	13/16	13/32	0.97
PN11 1/2 1/2		-	1/2							

Recommended Tightening Torque

Thread	Norm Reference	Tightening Torque (lb-ft)													
		M3x0.5	M5x0.8	M6x1	M7x1	M8x1	M10x1	M12x1.25	M12x1.5	10-32	1/8	1/4	3/8	1/2	
NPTF PTFE Pre-Coated	ANSI/ASME B1.20.3	-	-	-	-	-	-	-	-	-	-	8.5	10.5	13.5	18.5
UNF with O-Ring	ANSI/ASME B1.1	-	-	-	-	-	-	-	-	-	0.59	-	-	-	-
easyThread	Universal Thread	-	-	-	-	-	-	-	-	-	-	0.89	1.11	1.84	2.58
Gas Parallel with O-Ring	UNI - ISO 228/1	-	-	-	-	-	-	-	-	-	-	0.89	1.11	1.84	2.58
Gas Taper PTFE Pre-Coated	UNI - ISO 7/1	-	-	-	-	-	-	-	-	-	-	1.84	2.58	4.43	8.85
Gas Parallel with Plastic Ring	UNI - ISO 228/1	-	-	-	-	-	-	-	-	-	-	1.48	2.21	2.95	5.9
Metric with O-Ring	ISO R/262	0.59	0.59	0.59	0.59	-	-	1.11	1.11	-	-	-	-	-	-