

Metal Push-to-Connect Fitting - Union Tee (PN29)

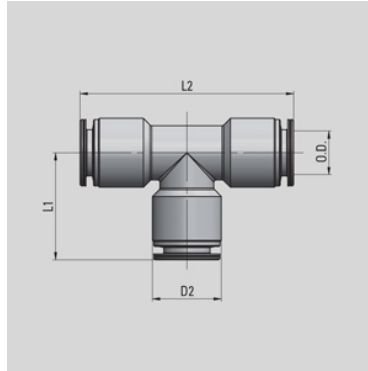

Part Number	Tube OD	D2	L1	L2	OZ
PN29 1/8 1/8	1/8"	0.275	0.59	1.181	0.194
PN29 5/32 5/32	5/32"	0.354	0.669	1.338	0.441
PN29 1/4 1/4	1/4"	0.472	0.787	1.574	0.723
PN29 5/16 5/16	5/16"	0.551	0.846	1.692	0.988
PN29 3/8 3/8	3/8"	0.629	0.964	1.929	1.482
PN29 1/2 1/2	1/2"	0.748	1	2	2.081

Recommended Tightening Torque

Thread	Norm Reference	Tightening Torque (lb-ft)													
		M3x0.5	M5x0.8	M6x1	M7x1	M8x1	M10x1	M12x1.25	M12x1.5	10-32	1/8	1/4	3/8	1/2	
NPTF PTFE Pre-Coated	ANSI/ASME B1.20.3	-	-	-	-	-	-	-	-	-	-	8.5	10.5	13.5	18.5
UNF with O-Ring	ANSI/ASME B1.1	-	-	-	-	-	-	-	-	0.59	-	-	-	-	
easyThread	Universal Thread	-	-	-	-	-	-	-	-	-	0.89	1.11	1.84	2.58	
Gas Parallel with O-Ring	UNI - ISO 228/1	-	-	-	-	-	-	-	-	-	0.89	1.11	1.84	2.58	
Gas Taper PTFE Pre-Coated	UNI - ISO 7/1	-	-	-	-	-	-	-	-	-	1.84	2.58	4.43	8.85	
Gas Parallel with Plastic Ring	UNI - ISO 228/1	-	-	-	-	-	-	-	-	-	1.48	2.21	2.95	5.9	
Metric with O-Ring	ISO R/262	0.59	0.59	0.59	0.59	-	-	1.11	1.11	-	-	-	-	-	